

Sheet E21.49

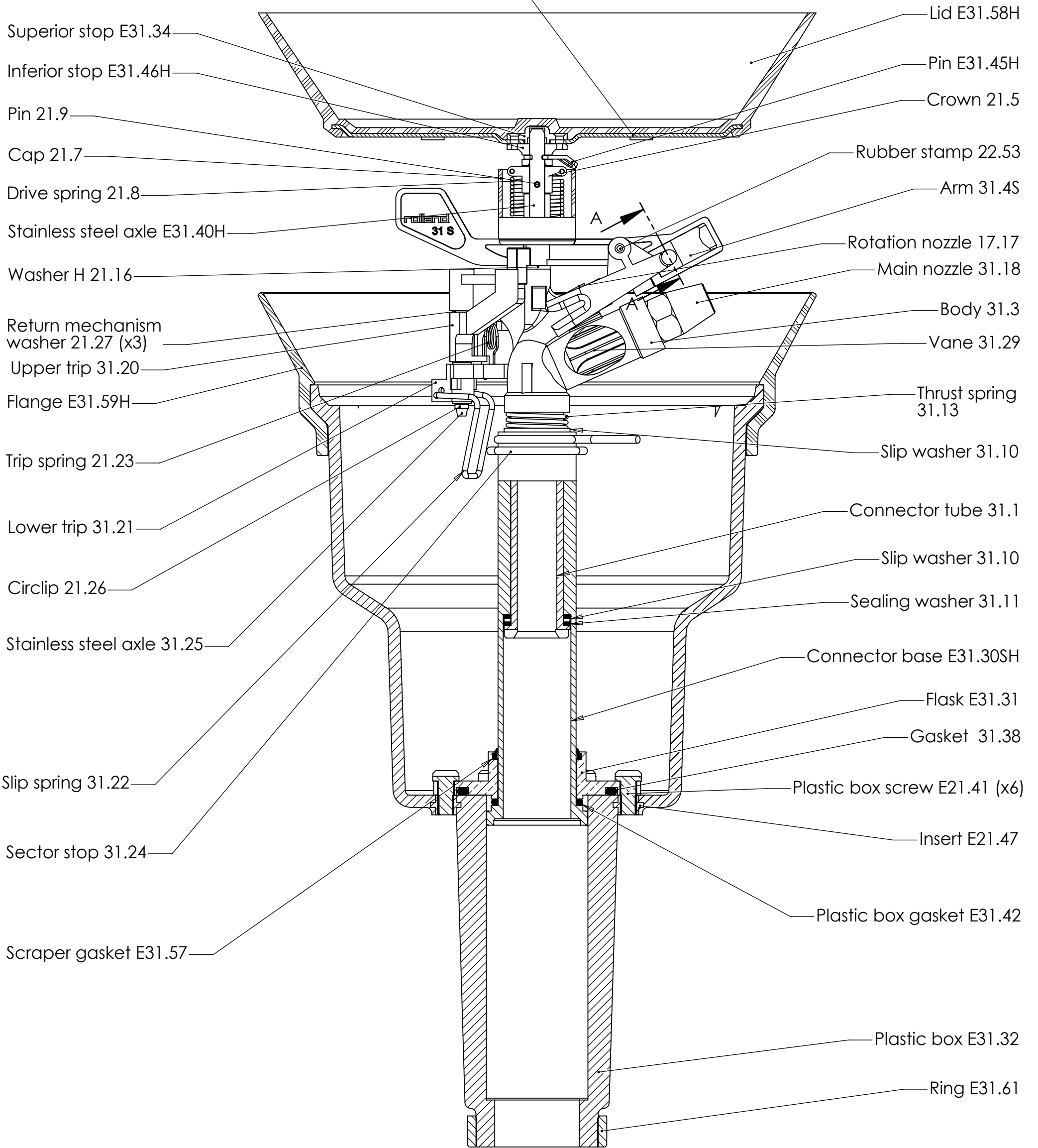

- Superior stop E31.34
- Inferior stop E31.46H
- Pin 21.9
- Cap 21.7
- Drive spring 21.8
- Stainless steel axle E31.40H
- Washer H 21.16
- Return mechanism washer 21.27 (x3)
- Upper trip 31.20
- Flange E31.59H
- Trip spring 21.23
- Lower trip 31.21
- Circlip 21.26
- Stainless steel axle 31.25
- Slip spring 31.22
- Sector stop 31.24
- Scraper gasket E31.57

- Lid E31.58H
- Pin E31.45H
- Crown 21.5
- Rubber stamp 22.53
- Arm 31.4S
- Rotation nozzle 17.17
- Main nozzle 31.18
- Body 31.3
- Vane 31.29
- Thrust spring 31.13
- Slip washer 31.10
- Connector tube 31.1
- Slip washer 31.10
- Sealing washer 31.11
- Connector base E31.30SH
- Flask E31.31
- Gasket 31.38
- Plastic box screw E21.41 (x6)
- Insert E21.47
- Plastic box gasket E31.42
- Plastic box E31.32
- Ring E31.61

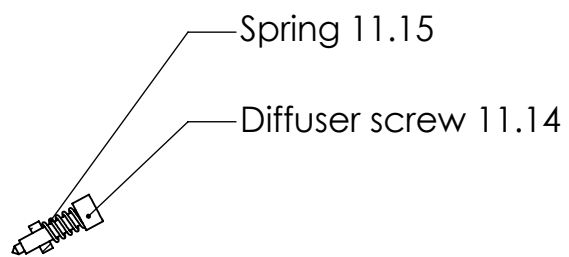

CROSS SECTION A-A
SCALE 1 : 2

Ind: A	Date: 03/05/05	
Dessiné par: DM	Vérifié par: DM	1:3
rolland ARROSEURS / SPRINKLERS		Pop Up Part Circle E31SH
235 ROUTE DE LA BIOLLE 73410 MOGNARD . SAVOIE . FRANCE TEL: (33) 04.79.54.72.50 FAX: (33) 04.79.54.72.48 http://www.rolland-sprinklers.com email: info@rolland-sprinklers.com		Ce plan est la propriété de la société ROLLAND, toute reproduction est interdite.